

LO-CAT[®] PROCESS

H₂S OXIDATION SYSTEM FOR
WATER TREATMENT FACILITIES

H₂S



A new water treatment facility in the town of Jupiter, Florida, was causing a serious odor problem. H₂S removed from the purified water was being released into the atmosphere. Complaints about the odor came from the residences and businesses downwind of the treatment plant.

A turnkey LO-CAT[®] Hydrogen Sulfide Oxidation System designed to process 30,000 CFM of air containing 250 ppm of H₂S solved this problem.

Due to the scarcity of fresh water available for treatment by conventional means, the town of Jupiter chose to be the first in southeast Florida to drill into the Floridan aquifer, located approximately 1,200 feet below ground.

A 6 MGD treatment plant, consisting of reverse osmosis, air stripping and chemical treatment, was designed by the engineering firm retained by the town. Because the well water is brackish and contains dissolved H₂S, it must undergo pre-treatment prior to entering the town's regional water distribution system.

In the reverse osmosis process, the aquifer's brackish water is pressurized and forced through a semipermeable membrane. The dissolved CO₂ and H₂S pass through the membrane along with the purified water. The purified water is then passed through an air stripper to remove the dissolved H₂S and CO₂.

Because the well contained more H₂S than anticipated, the effluent air from the air stripper created a serious odor problem in the residential area surrounding the treatment plant.

Gas Technology Products

Merichem Chemicals &
Refinery Services LLC

LO-CAT[®] PROCESS

H₂S OXIDATION SYSTEM FOR
WATER TREATMENT FACILITIES

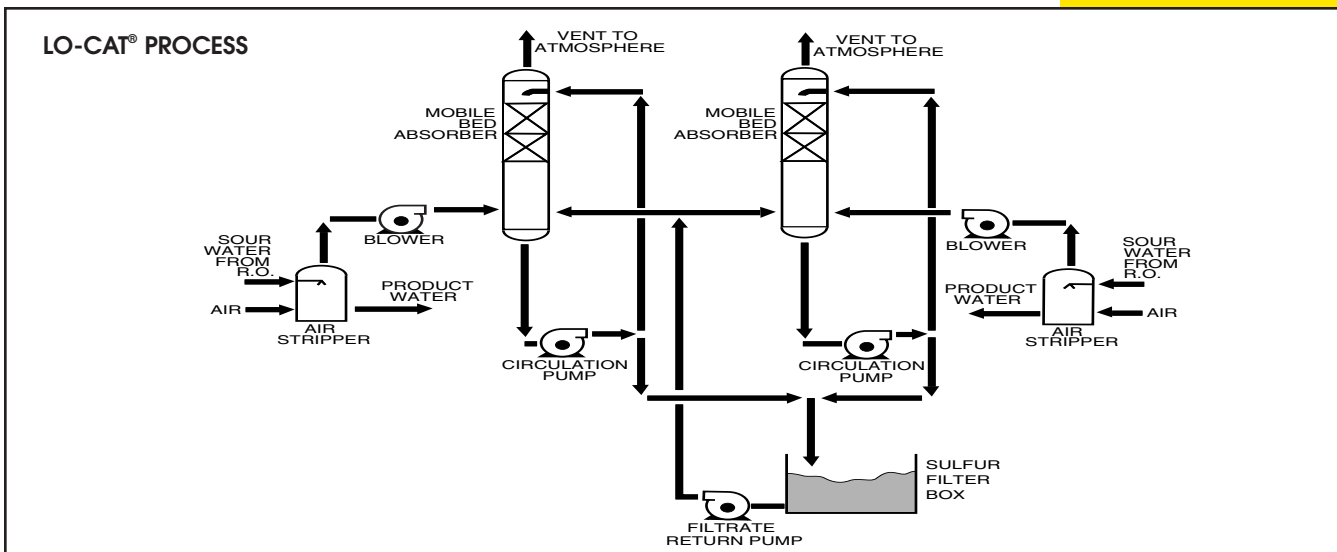

After a comprehensive investigation, the engineers selected the LO-CAT[®] Hydrogen Sulfide Oxidation Process based on its economy, environmental safety and demonstrated capability of continuous high H₂S removal efficiencies.

The town of Jupiter retained the LO-CAT to provide a turnkey LO-CAT system having a H₂S removal efficiency of 98%.

The town also specified that the entire system had to be designed, installed, and meet the guaranteed removal efficiency within 22 weeks after award of the contract. The LO-CAT met all objectives.

In the LO-CAT process, the H₂S is converted to innocuous, elemental sulfur by the use of an environmentally safe chelated iron catalyst in accordance with the following equation:

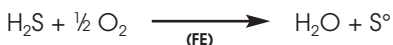

In this equation, the oxidant is the oxygen contained in the air stream. Consequently, the only chemical consumptions are replacement of a small amount of chelated iron lost in the sulfur filter cake, and caustic

addition, to maintain the pH of the catalytic solution in the mildly alkaline range.

The LO-CAT unit for the town of Jupiter consists of two mobile bed absorbers, each with a diameter of 7'6" and a 55' discharge height, and a common sulfur filtration system capable of producing a 30 wt% sulfur cake.

The sulfur cake is currently being mixed with the lime sludge produced in the existing lime softening systems; however, the sulfur could also be disposed of in the local sanitary landfill.

The system, designed to process 30,000 CFM of air containing 250 ppm of H₂S, was installed and met the guaranteed H₂S removal efficiency of 98% just 22 weeks after the award of the contract.

Gas Technology Products

Merichem Chemicals & Refinery Services LLC

846 East Algonquin Road
Suite A100
Schaumburg, IL 60173
Phone: (847) 285-3850
Fax: (847) 285-3888/3889
www.gtp-merichem.com

Japan Office:

Phone: (81) 3-5289-4530
Fax: (81) 33-255-5181

